

Instruction Manual

Range of safety modules for control of emergency stops,
mechanical and electronic safety sensors



OTHER PRODUCTS : FORCE 0 AND IP 69K TOUCH BUTTON



COMITRONIC-BTI THE LEADER IN STAND-ALONE SAFETY SWITCHES



Safety boxes

CONTENTS

| | |
|---|-----------|
| AWAX 26XXL-485 | 4 |
| 1. Technological benefits | 4 |
| 2. Schematic diagram of a three-door control | 4 |
| 3. Installation configuration of §2 | 5 |
| 4. Detection of a power supply error | 5 |
| 5. Technical features | 5 |
| AWAX 26XXL-T6 | 6 |
| 1. Technological benefits | 6 |
| 2. Comparison of short circuit detection systems in cables | 6 |
| 3. Schematic diagram of a two-door control with short-circuit detection | 7 |
| 4. Assembly precautions | 7 |
| 5. T6 Version dimensions | 8 |
| 6. T6BR terminal block dimensions | 8 |
| 7. Main Features | 8 |
| AWAX 26XXL | 9 |
| 1. Technological benefits | 9 |
| 2. Wiring diagram and assembly precautions | 9 |
| 3. Dimensions | 10 |
| 4. Main Features | 10 |
| AWAX 45XXL2 | 11 |
| 1. Technological benefits | 11 |
| 2. Wiring diagram and assembly precautions | 11 |
| 3. Dimensions | 12 |
| 4. Main Features | 12 |
| CO13 XXL | 13 |
| 1. Technological benefits | 13 |
| 2. Single-channel diagram | 13 |
| 3. Two-channel diagram | 13 |
| 4. Dimensions | 14 |
| 5. Main Features | 14 |
| COM 3C | 15 |
| 1. Technological benefits | 15 |
| 2. Schematic diagram | 15 |
| 3. Dimensions | 16 |
| 4. Main Features | 16 |
| C4 SX AND C5 SX | 17 |
| 1. Technological benefits | 17 |
| 2. Schematic diagram C4SX with API | 17 |
| 3. Schematic diagram C4SX with AWAX | 17 |
| 4. Schematic diagram of C5SX with safety light curtain | 18 |
| 5. Main Features | 18 |
| C4 CK | 19 |
| 1. Technological benefits | 19 |
| 2. Example of a schematic diagram of C4CK-A: Machine in operation | 19 |
| 3. Example of a schematic diagram of C4CK-A: downgraded mode | 20 |
| 4. Main Features | 20 |

Safety boxes

CONTENTS

| | |
|--|-----------|
| RELTRONIC 6SX | 21 |
| 1.Technological benefits | 21 |
| 2.Schematic diagram | 21 |
| 3.Dimensions | 21 |
| SPEEDTRONIC | 22 |
| 1.Technological benefits | 22 |
| 2.Example of a schematic diagram | 22 |
| 3.Dimensions | 22 |
| 4.Main Features | 23 |
| Safety boxes:Wiring regulations and standard dimensions | 24 |
| 1.Principle of wiring motor control contacts | 24 |
| 2.Dimensions of 22.5mm Model | 24 |
| 3.Dimensions of 45 mm Model | 24 |
| AWAX 26XXL-485 DECLARATION OF CONFORMITY | 25 |
| AWXX 26XXL-T6 DECLARATION OF CONFORMITY | 26 |
| AWAX 26XXL DECLARATION OF CONFORMITY | 27 |
| AWAX 45XXL2 DECLARATION OF CONFORMITY | 28 |
| CO13 XXL DECLARATION OF CONFORMITY | 29 |
| COM 3C DECLARATION OF CONFORMITY | 30 |
| C4 SX, C5 SX, C4 CK DECLARATION OF CONFORMITY | 31 |
| RELTRONIC 6SX DECLARATION OF CONFORMITY | 32 |
| SPEEDTRONIC DECLARATION OF CONFORMITY | 33 |

Self-monitoring safety box with Modbus RTU diagnostics: AWAX 26XXL-485

up to PLe
acc. ISO 13849-1



Low consumption monitoring inputs

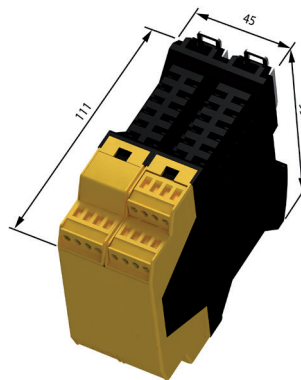

Management of up to 12 sensors
on a 2-wire network



Automatic connection to
network sensors

Machine safety management system with decoding of the Modbus network's diagnostic outputs

1. Technological benefits

- Monitoring of ANATOM78S-485-MKT sensor safety contacts for access control
- Connection to removable terminal blocks
- Modbus master network management of sensors for ANATOM78S-485-MKT diagnostic outputs
- Two redundant inputs for sensor safety control
- Two connections for ModBus
- A connection for the configuration
- 3 Safety lines and an auxiliary NC line: Model 26XXL = 8A/250V, Model 26XXL-T6 = 6A/250V
- 12 PNP/200 mA outputs for the status of each sensor + alarm
- 24 VAC or DC power supply

2. Schematic diagram of a three-door control

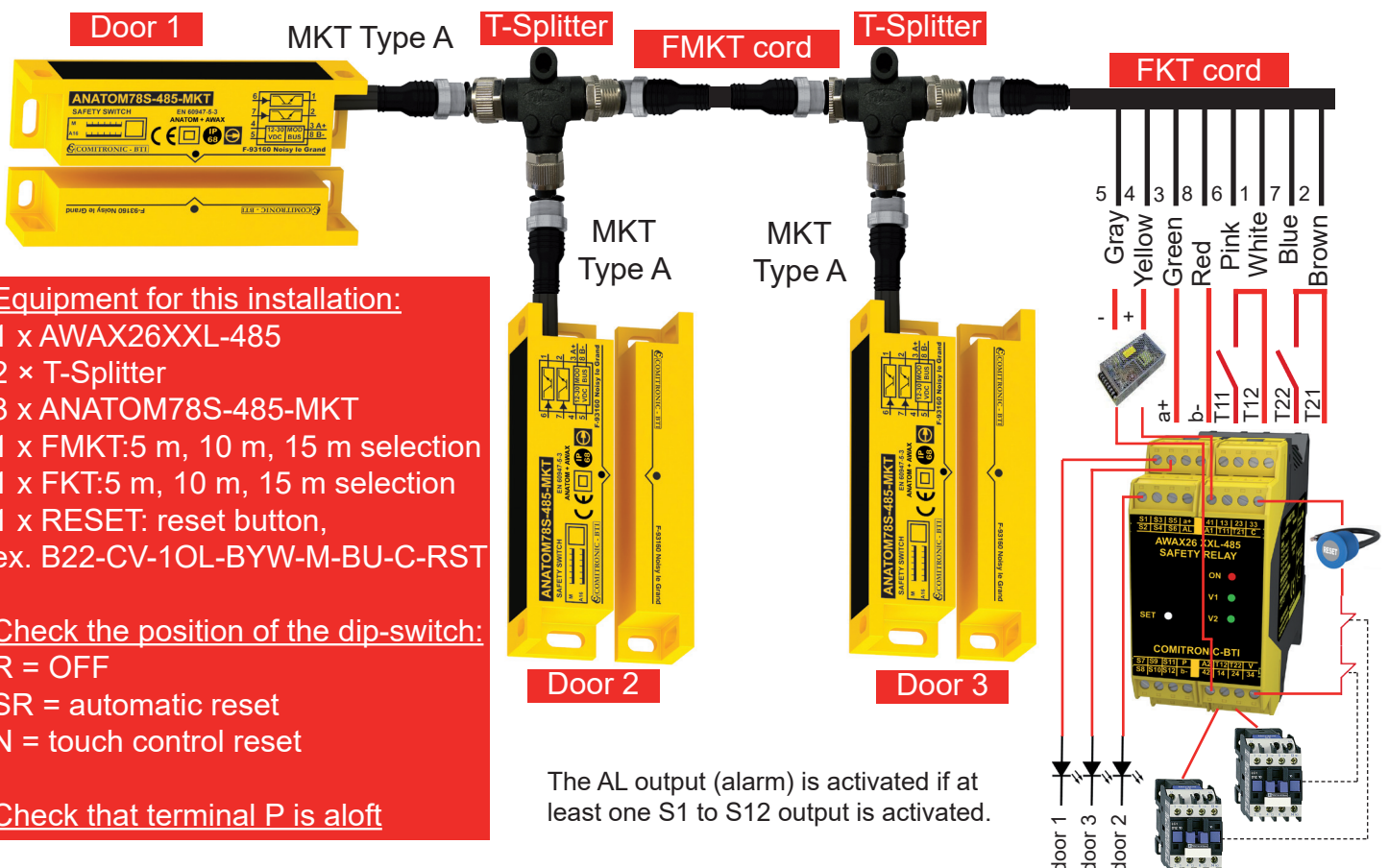

Equipment for this installation:
 1 x AWAX26XXL-485
 2 x T-Splitter
 3 x ANATOM78S-485-MKT
 1 x FMKT: 5 m, 10 m, 15 m selection
 1 x FKT: 5 m, 10 m, 15 m selection
 1 x RESET: reset button,
 ex. B22-CV-10L-BYW-M-BU-C-RST

Check the position of the dip-switch:
 R = OFF
 SR = automatic reset
 N = touch control reset

Check that terminal P is aloft

The AL output (alarm) is activated if at least one S1 to S12 output is activated.

Self-monitoring safety box with Modbus RTU diagnostics:AWAX 26XXL-485

3.Installation configuration of §2

During installation, the memories of the ANATOM78S-485-MKT and the AWAX26XXL-485 are blank. It is necessary to program the networking. Two settings are available: a terminal P (program) and a dip-switch R (reset) located at the back of the unit.

3.1 Add sensors to the network

- Link a push button between terminal P and A1
- Connect the first sensor to the T-SPLITTER and check that its LED flashes (the door must be open)
- Press the button, the SET LED flashes, which transfers the first address. Check that the LED sensor stops flashing and check that the S1 output switches.
- Link the second sensor, press the button and perform the same steps as before.
- Link the third sensor, press the button and perform the same steps as before.
- Remove the push button.

3.2 Remove sensors from the network

If, for example, the no. 3 sensor is then removed, the AWAX26XXL-485 LED pulses 3 times, therefore, the number of pulses indicates which sensor is absent, remove it from the T-SPLITTER. Move the dip-switch R to ON to delete position no. 3 from the memory. Once cleared, the sensor with the no. 3 address can no longer be reconnected.

4.Detection of a power supply error

When the supply voltage is out of specification, the SET LED flashes rapidly.

5.Technical specifications

| | |
|----------------------------------|---|
| Supply voltage | 20 to 32 VDC |
| Power supply without Modbus | 150 mA |
| Power supply with Modbus | +10 mA maximum for 60 ms |
| Diagnostic output specifications | 12 x 200mA PNP protected outputs |
| Alarm output specification | 2 A PNP protected |
| Safety contacts specifications | 13/14, 23/24, 33/34:NO 8A/250V 41/42:NC 8A/250V |
| Input control and consumption | T11/12:45mA and T21/T22:45mA |
| Settings | Terminal P: program mode (addressing) Dip-switch R: reset mode (clears memory) SR/N dip switch: SR automatic or N manual reset mode |
| Operating temperature | -25°C to +60°C (-13° to +140° F) |
| Sealing | IP 20 |
| Material | Polyamide 6 |
| Weight with packaging | 350 grams |

Self-monitoring safety box versatile:AWAX 26XXL-T6



up to PLe acc. ISO 13849-1

Low consumption monitoring inputs 18.5 mA

Breaking capacity 4 x 6 A

Controls the sensors to Acotom process, emergency stops, interlocking, etc.

Reset: manual or automatic

Risk period very short 5 ms

SIL 3 PL e / cat.4

Machine safety management system with redundant inputs and DLC short circuit protection*

1. Technological benefits

- Monitoring of safety contacts of ACOTOM® process sensors for access control
- Compatible with mechanical switches and emergency stops
- Suitable for dusty environments
- Redundant inputs with low power consumption of 18.5 mA
- Channel indicator status: diagnostics aid with high luminosity LED
- Dip-Switch automatic or manual reset selection mode
- 50% reduction of power consumption in "work" position
- Version T6: removable screw terminal blocks with copper contacts
- Version T6C: push-in terminal blocks (without screw)
- Quick detection of short circuit in the cables by the DLC circuit*
- Controlled automatic or manual reset, adjustable with dip-switch (N/SR)
- 3 NO safety lines and NC 6A/250V auxiliary line
- 24 VAC or DC power supply

*DLC system

- Quick detection of short circuits in the cables by an ultra-fast electronic detector which allows for a maximum current of 300 mA in the cables
- Availability of the product immediately after the disappearance of the short circuit

2. Comparison of short circuit detection systems in cables

| | Compatible in a dusty environment | Speed of detection | Rapid return to service | Cost of the device | Loss of productivity |
|-----------------|-----------------------------------|--------------------|-------------------------|--------------------|----------------------|
| Fuse | no | yes | very high | medium | very high |
| Resettable fuse | no | no | high | low | high |
| DLC | yes | yes | very fast | low | none |
| OSSD | yes | yes | low to high | high | low to high |

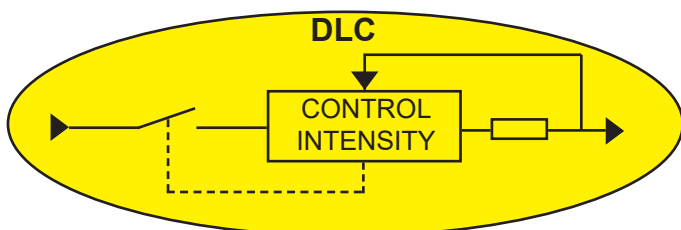

Ultra-fast 5ms safety procedure
=
more products monitored without increasing the safety distance

Self-monitoring safety box versatile:AWAX 26XXL-T6

3.Schematic diagram of a two-door control with short-circuit detection

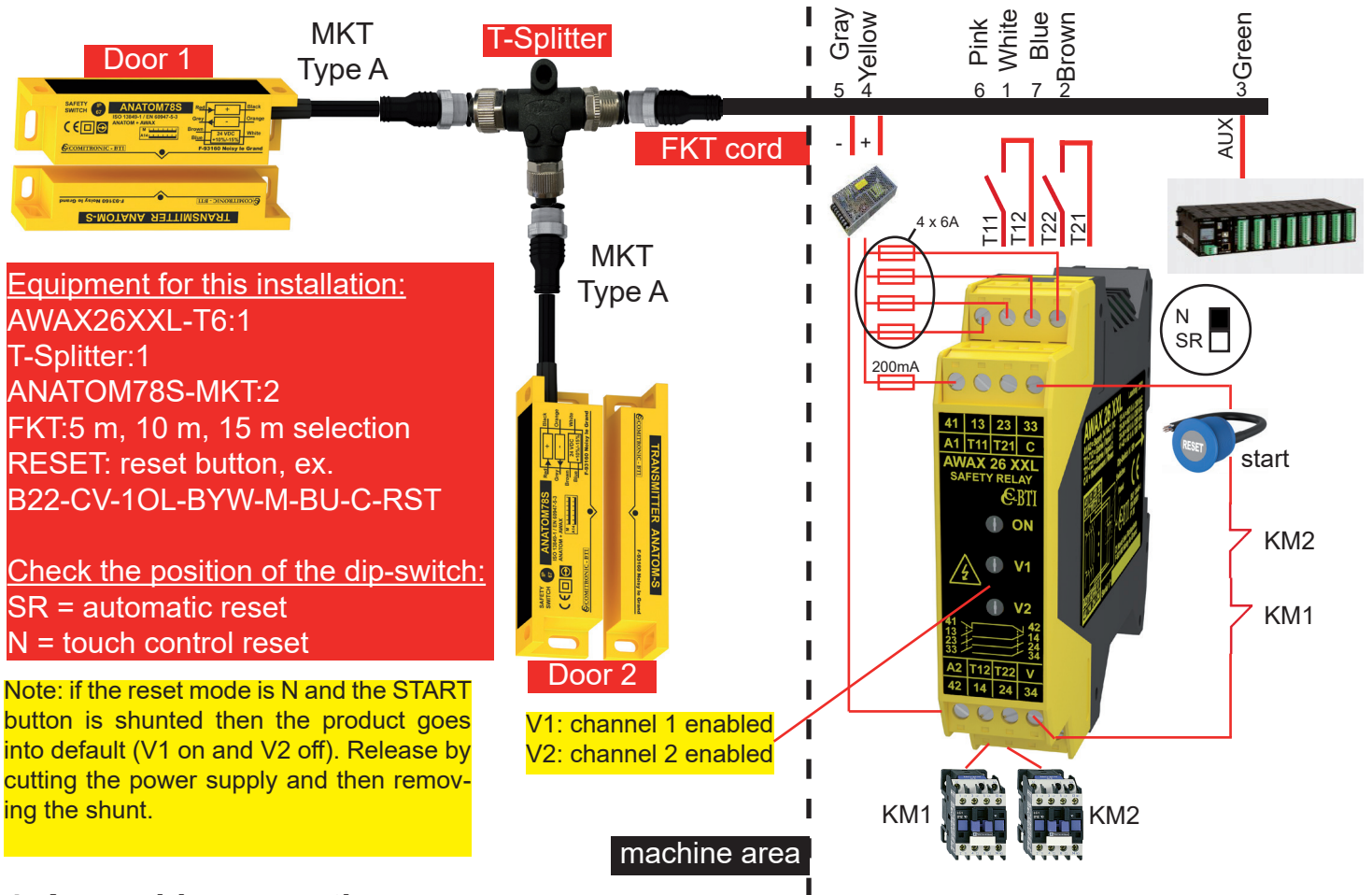

4. Assembly precautions

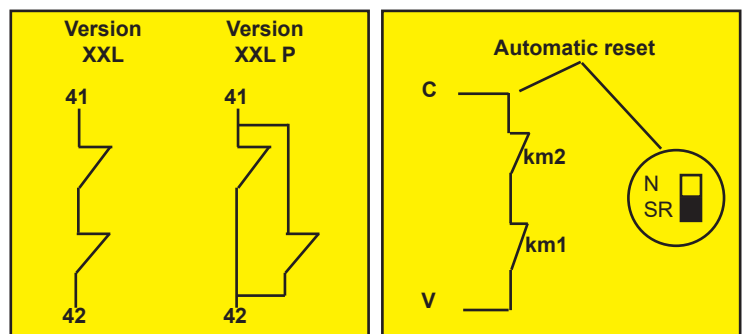
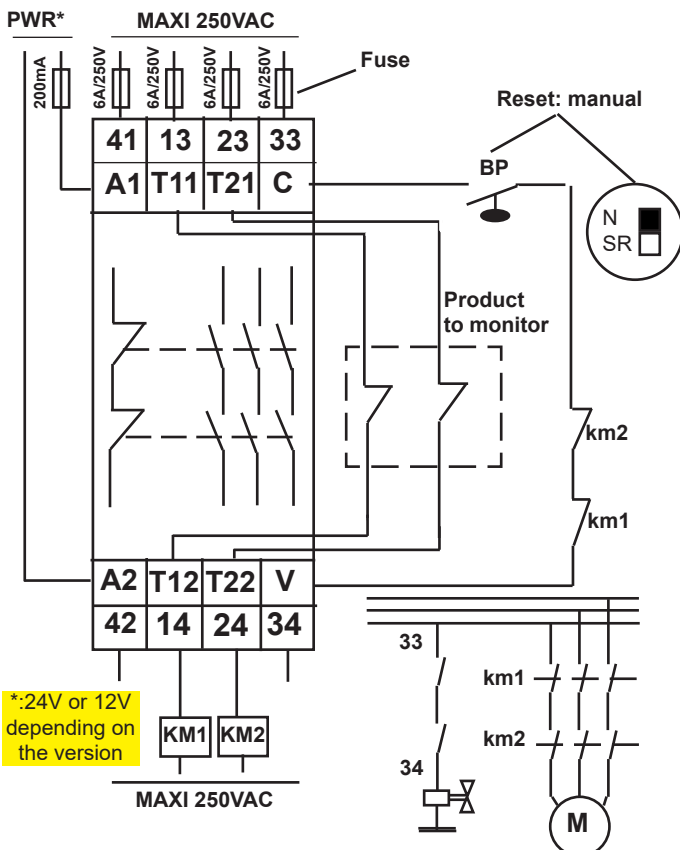

The user must install the external fuses as shown in the diagrams. Housing 22.5 mm snap-on symmetrical 35 mm DIN rail according to DIN 50022. The terminal tightening torque is 0.68 Nm. The maximum diameter of wiring is 2.08 mm² (14 AWG). In order to provide operators with sufficient electrical protection against electric shock, the wiring between AWAX26XXL-T6 and other system components, (e.g. emergency stop buttons), must be done using 250V-rated voltage cables. This product must be installed in an IP 54 box.

AWAX26XXL-T6: must be tested yearly

Self-monitoring safety box versatile:AWAX 26XXL-T6

5. Dimensions of Version T6

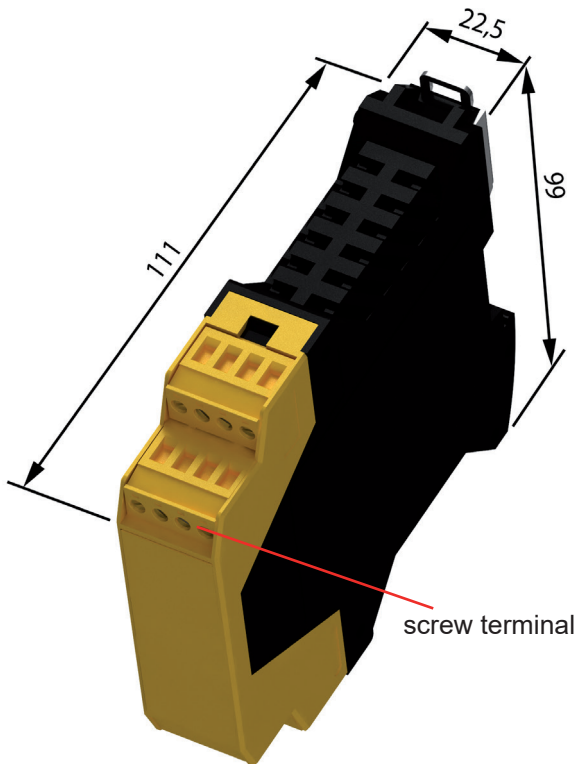

6. T6BR Terminal block dimension

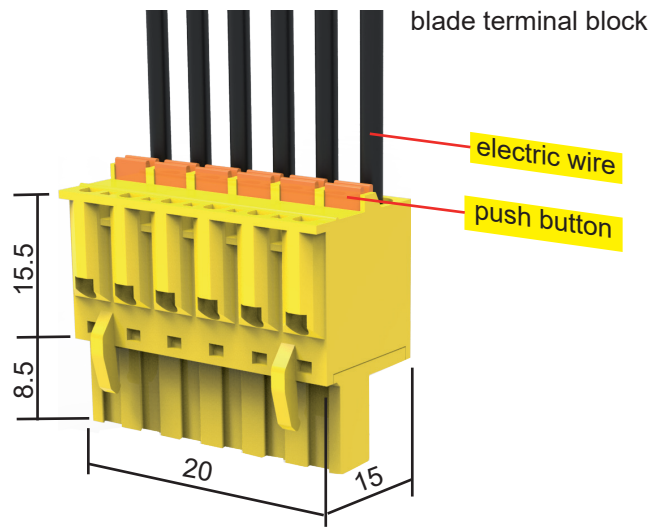

Standard with screw terminal block:AWAX26XXL-T6
Standard with blade terminal block:AWAX26XXL-T6BR

7.General specifications

| | |
|--|--|
| Supply voltage PELV/SELV IEC 60204-1 | 20~30 VAC 50/60 Hz et 20~30 VDC or 12 VDC Class 2 power supply or transformer protected by a 300 mA fuse, UL listed |
| In-rush / working current | 90 mA / 50 mA |
| Electrical connection / tensioning | 14 AWG max (2.08mm ²) 250V min / 0.68 Nm |
| Short circuit protection | Current limitation (DLC) at 300 mA |
| Safety contacts specifications IEC 60947-5-1 | 13/14, 23/24, 33/34:NO 6 A/250 V pilot duty XXL Version: 41/42:NC Series 6A/250V pilot duty XXLP Version: 41/42 NC // 6A/250V pilot duty |
| Input control and consumption | T12, T22:37 mA max, 18.5 mA (working) |
| Reset Mode | Dip-switch on the back of product SR: automatic N: manual with collage monitoring |
| Duration of Risk/Time of Response Minimum duration of a cycle/maximum frequency | SR mode:DR=5 ms / TR~15 ms Tcy = 400 ms / Fmax = 2.5 Hz |
| Diagnostics | ON LED (red): power supply V1 LED (green):Channel 1 enabled (T11/T12) V2 LED (green):Channel 2 enabled (T21/T22) |
| IEC 60068-2-1/2 Operating temperature | -25°C to +70°C (-13° to +158° F) |
| Water tightness / weight | IP 20 / 180 grams |
| Material / dimensions | Polyamide 6 / 22.5 x 100 x 111 mm |
| Periodic testing | 1/year |

Self-monitoring safety box versatile:AWAX 26XXL

up to PLe
acc. ISO 13849-1

Low consumption monitoring inputs
45 mA

Breaking
capacity 4 x 8 A



Controls the sensors to
Acotom process, emergency stops, inter-
locking, etc.

Reset: manual
or automatic

Certified
UL/CSA/ETL

SIL 3
PL e / cat.4



Machine safety management system with redundant inputs and DLC short circuit protection

1. Technological benefits

- Monitoring of safety contacts of ACOTOM® process sensors for access control
- Compatible with mechanical switches and emergency stops
- Suitable for dusty environments
- Channel indicator status: diagnostics aid with high luminosity LED
- Dip-Switch automatic or manual reset selection mode
- 50% reduction of power consumption in "work" position
- Removable screw terminal blocks with copper contacts
- Quick detection of short circuit in the cables by the DLC circuit (see AWAX26XXL-T6 description)
- Controlled automatic or manual reset, adjustable with dip-switch (N/SR)
- 3 NO safety lines and NC 8A/250V auxiliary line

2. Wiring diagram and assembly precautions

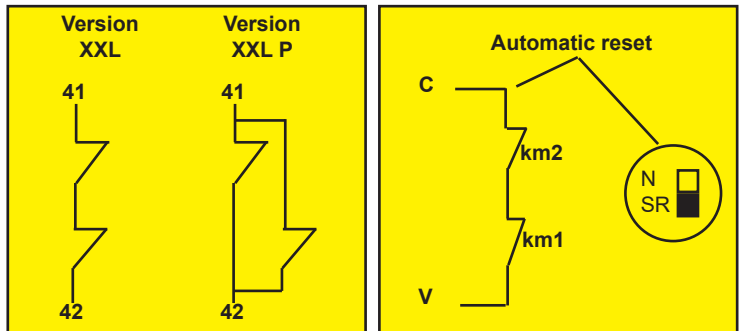
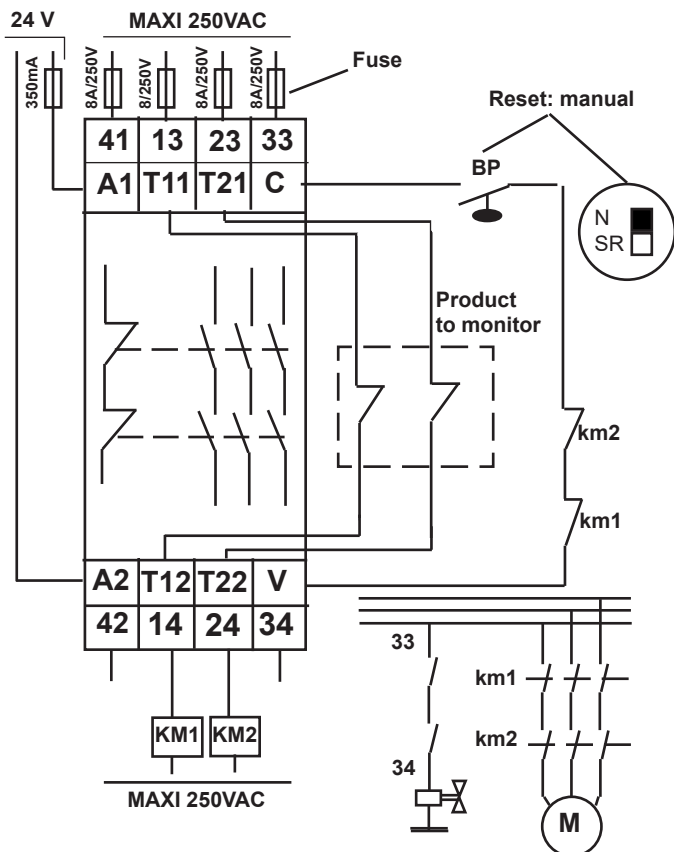

The user must install the external fuses as shown in the diagrams. Housing 22.5 mm snap-on symmetrical 35 mm DIN rail according to DIN 50022. The terminal tightening torque is 0.68 Nm. The maximum diameter of wiring is 2.08 mm² (14 AWG). In order to provide operators with sufficient electrical protection against electric shock, the wiring between AWAX26XXL and other system components, (e.g. emergency stop buttons), must be done using 250V-rated voltage cables. This product must be installed in an IP 54 box. AWAX26XXL: should be tested once a month.

Note: if the reset mode is N and the START button is shunted then the product goes into default (V1 on and V2 off). Release by cutting the power supply and then removing the shunt.

Self-monitoring safety box versatile:AWAX 26XXL

3. Dimensions

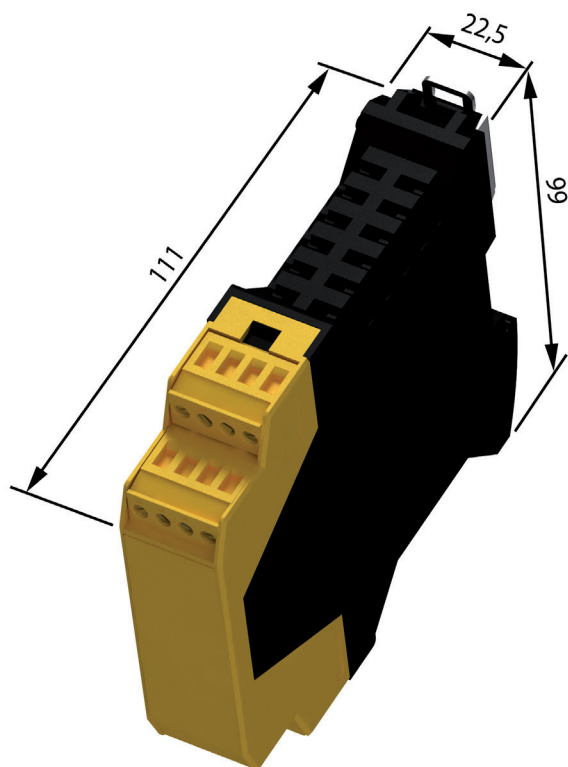

Dimensions of a BR terminal block

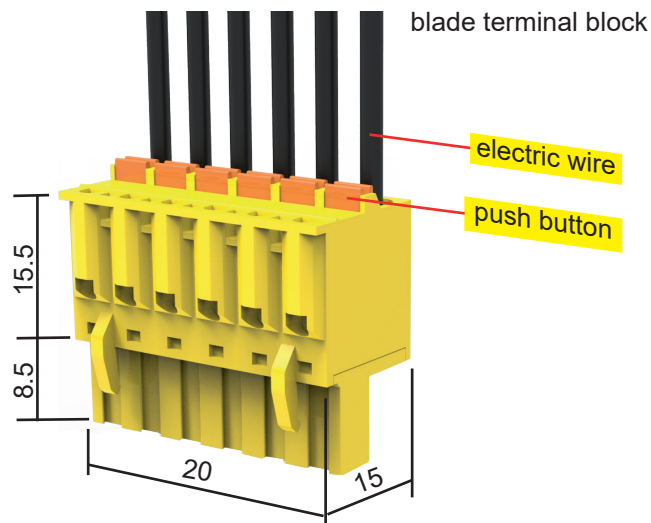

Standard with screw terminal block:AWAX26XXL
Standard with blade terminal block:AWAX26XXL-BR

4. General specifications

| | |
|--|--|
| Supply voltage PELV/SELV IEC 60204-1 | 21~26 VAC 50/60 Hz or VDC Class 2 power supply or transformer protected by a 4A max. fuse, UL listed |
| In-rush / working current (DC) | 180 mA / 100 mA |
| Electrical connection / tensioning | 14 AWG max (2.08mm ²) 250V min / 0.68 Nm |
| Short circuit protection | Current limitation (DLC) at 350 mA |
| Safety contacts specifications IEC 60947-5-1 | 13/14, 23/24, 33/34:NO 8 A/250 V pilot duty XXL Version: 41/42:NC Series 8A/250V pilot duty XXLP Version: 41/42 NC // 8A/250V pilot duty |
| Input control and consumption | T12, T22:80 mA, 45 mA (working) |
| Reset Mode | Dip-switch on the back of product SR: automatic N: manual with collage monitoring |
| Duration of Risk/Time of Response Minimum duration of a cycle / maximum frequency | SR mode:DR=5 ms / TR~20 ms Tcy = 400 ms / Fmax = 5 Hz |
| Diagnostics | ON LED (red): power supply V1 LED (green):Channel 1 enabled (T11/T12) V2 LED (green):Channel 2 enabled (T21/T22) |
| IEC 60068-2-1/2 Operating temperature | -20°C to +60°C (-4° to +140° F) |
| Water tightness / weight | IP 20 / 180 grams |
| Material / dimensions | Polyamide 6 / 22.5 x 100 x 111 mm |
| Periodic testing | 1/month |

Self-monitoring safety box versatile:AWAX 25XXL2

up to PLe
acc. ISO 13849-1

Power supply
85~265 VAC

Breaking
capacity 4 x 8 A



Controls the sensors to
Acotom process, emergency stops, inter-
locking, etc.

Reset: manual
or automatic

SIL 3
PL e / cat.4

Machine safety management system with redundant inputs and DLC short circuit protection

1. Technological benefits

- Monitoring of safety contacts of ACOTOM® process sensors for access control
- Compatible with mechanical switches and emergency stops
- Suitable for dusty environments
- Channel indicator status: diagnostics aid with high luminosity LED
- Dip-Switch automatic or manual reset selection mode
- 50% reduction of power consumption in "work" position
- Removable screw terminal blocks with copper contacts
- Quick detection of short circuit in the cables by the DLC circuit (see description AWAX26XXL-T6)
- Controlled automatic or manual reset, adjustable with dip-switch (N/SR)
- 3 NO safety lines and NC 8A/250V auxiliary line

2. Wiring diagram and assembly precautions

The user must install the external fuses as shown in the diagrams. Housing 22.5 mm snap-on symmetrical 35 mm DIN rail according to DIN 50022. The terminal tightening torque is 0.68 Nm. The maximum diameter of wiring is 2.08 mm² (14 AWG). In order to provide operators with sufficient electrical protection against electric shock, the wiring between AWAX300XXL and other system components, (e.g. emergency stop buttons), must be done using 300V-rated voltage cables. This product must be installed in an IP 54 box.

The product must be tested once a month.

Note: if the reset mode is N and the START button is shunted then the product goes into default (V1 on and V2 off). Release by cutting the power supply and then removing the shunt.

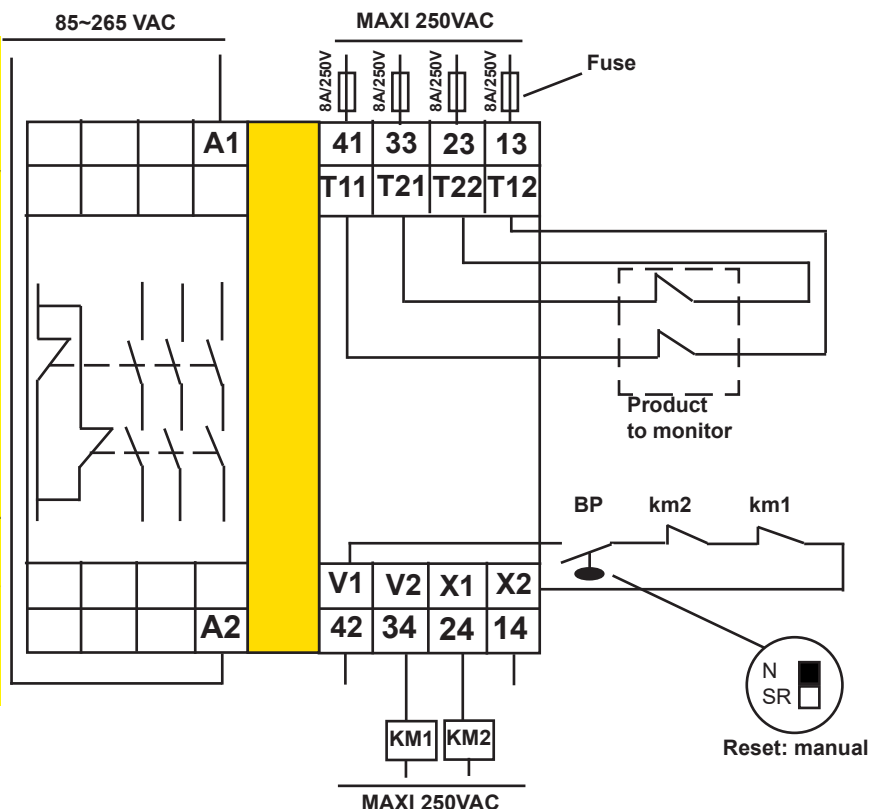

Self-monitoring safety box versatile:AWAX 25XXL2

3. Dimensions

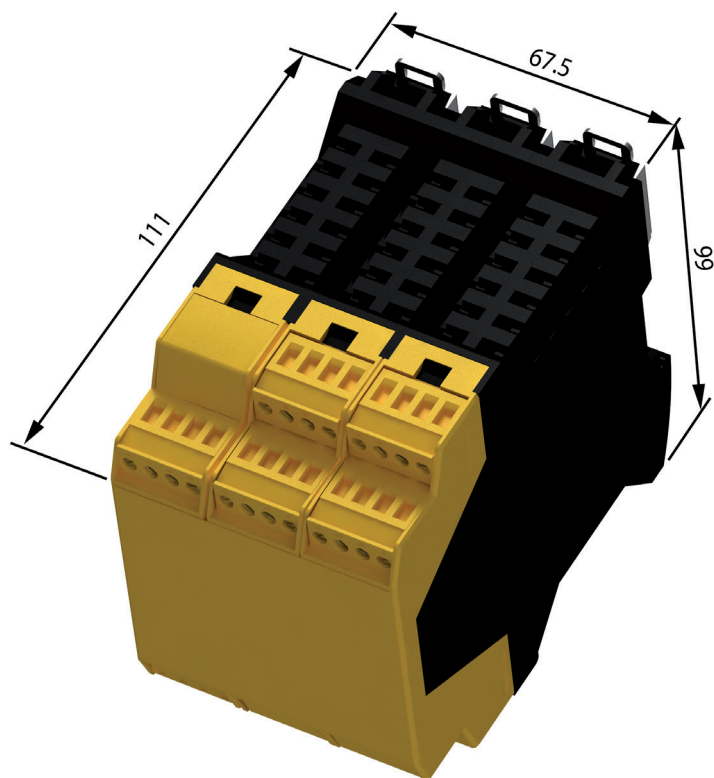

4. General specifications

| | |
|--|--|
| Supply voltage PELV/SELV IEC 60204-1 | 85~265 VAC 50/60 Hz |
| In-rush / working current (DC) | 180 mA / 100 mA |
| Electrical connection / tensioning | 14 AWG max (2.08mm ²) 250V min / 0.68 Nm |
| Short circuit protection | Current limitation (DLC) at 350 mA |
| Safety contacts specifications IEC 60947-5-1 | 13/14, 23/24, 33/34:NO 8 A/250 V pilot duty XXL Version: 41/42:NC Series 8A/250V pilot duty XXLP Version: 41/42 NC // 8A/250V pilot duty |
| Control Inputs | T12, T22 |
| Reset Mode | Dip-switch on the back of product SR: automatic N: manual with collage monitoring |
| Duration of Risk/Time of Response Minimum duration of a cycle / maximum frequency | SR mode:DR=5 ms / TR~20 ms Tcy = 400 ms / Fmax = 5 Hz |
| Diagnostics | ON LED (red): power supply V1 LED (green):Channel 1 enabled (T11/T12) V2 LED (green):Channel 2 enabled (T21/T22) |
| IEC 60068-2-1/2 Operating temperature | -20°C to +60°C (-4° to +140° F) |
| Water tightness / weight | IP 20 / 550 grams |
| Material / dimensions | Polyamide 6 / 22.5 x 100 x 111 mm |
| Periodic testing | 1/month |

Self-monitoring safety box

Versatile single and two-channel:CO13 XXL

up to PLe
acc. ISO 13849-1

Low con-
sumption inputs

Breaking
capacity 3 x 8 A



Check the
emergency stops

Reset: manual
or automatic

SIL 2
PL d / cat.3

Emergency stop management system with 1 or 2 contacts

1. Technological benefits

- Monitoring of safety contacts of mechanical switches and emergency stops
- Redundant inputs with low power consumption of 45 mA
- Channel indicator status: diagnostics aid with high luminosity LED
- Dip-Switch automatic or manual reset selection mode
- Controlled automatic or manual reset, adjustable using dip-switch
- 2 safety lines NO, an auxiliary line NC 8 A/250 V, an auxiliary contact NO 0.4 A/24 V
- 24 VAC or DC power supply
- Protection against severing of cables by opening of safety lines

2. Single-channel diagram

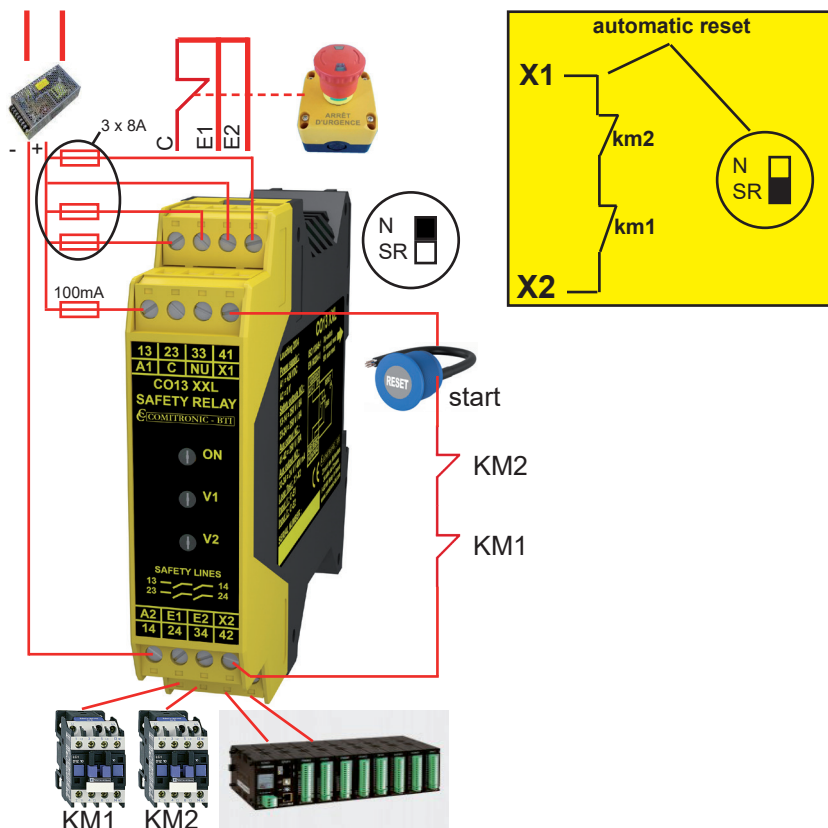

3. Two-channel diagram

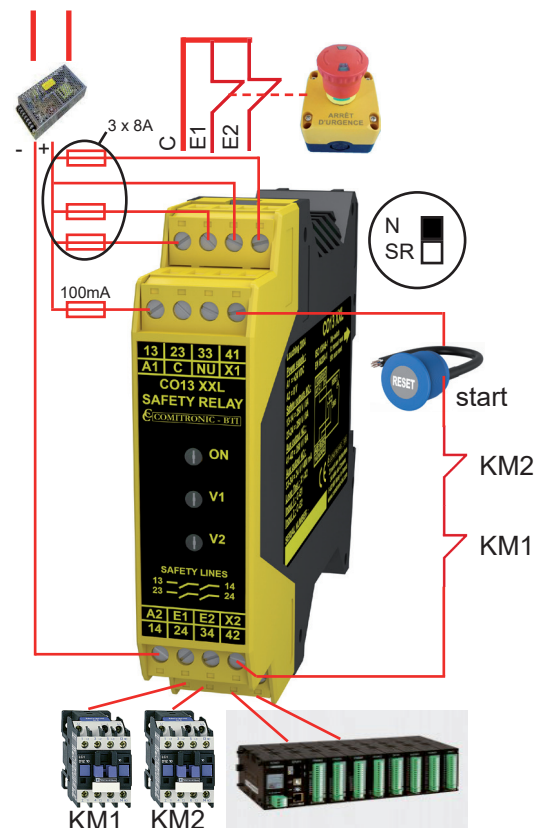

Self-monitoring safety box

Versatile single and two-channel:CO13 XXL

4. Dimensions

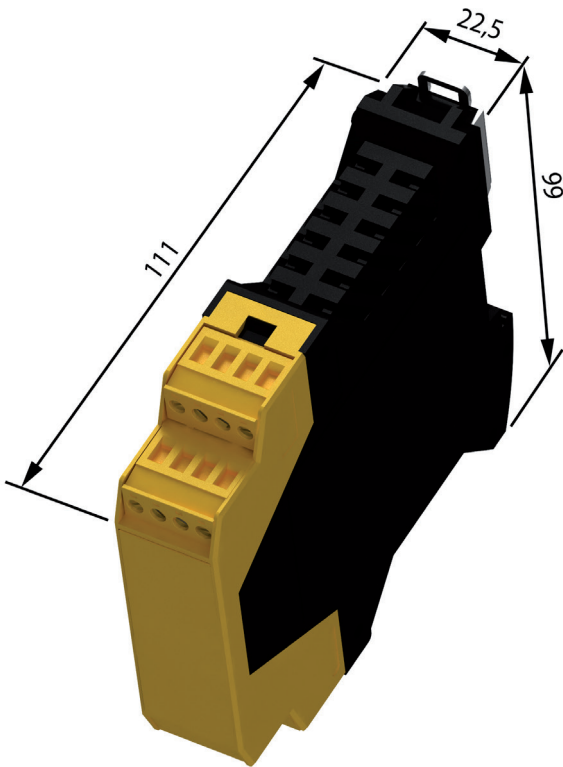

5. General specifications

| | |
|---|--|
| Supply voltage | 21~26 VAC/DC |
| Power supply | < 3.5 W (DC) ; < 4 VA (AC) |
| Electrical connection / tensioning | 14 AWG max (2.08mm ²) 250V min / 0.68 Nm |
| Safety contacts specifications IEC 60947-5-1 | 13/14, 23/24:NO 8 A/250 V pilot duty 41/42:NC // 8 A/250 V pilot duty 33/34:NO 400 mA/24V for API |
| Input control and consumption | E1, E2:45 mA |
| Reset Mode | Dip-switch on the back of product SR: automatic N: manual with collage monitoring |
| Time of Response | TR~20 ms |
| Diagnostics | ON LED (red): power supply V1 LED (green):Channel 1 enabled (C/E1) V2 LED (green):Channel 2 enabled (C/E2) |
| Operating temperature | -20°C to +60°C (-4° to +140° F) |
| Water tightness / weight | IP 20 / 125 grams |
| Material / dimensions | Polyamide 6 / 22.5 x 100 x 111 mm |
| Periodic testing | 1/year |

Two-hand control box COM3C

up to PLe
acc. ISO 13849-1

SIL 3
acc. to IEC 61508

Breaking
capacity 3 x 8 A



Check the
emergency stops

Reset: manual
or automatic

Press control with position control

1. Technological benefits

- Operator vigilance control by desynchronization of two control buttons
- Desynchronization duration of 300 ms
- Compatible with KOB101T mechanical buttons and bi-technology touch buttons
- Channel indicator status: diagnostics aid with high luminosity LED
- Test input for position control
- 2 NO safety lines, an auxiliary line NC 8 A/250 V
- 24 VAC or DC power supply
- Protection against severing of cables by opening of safety lines

2. Schematic diagram

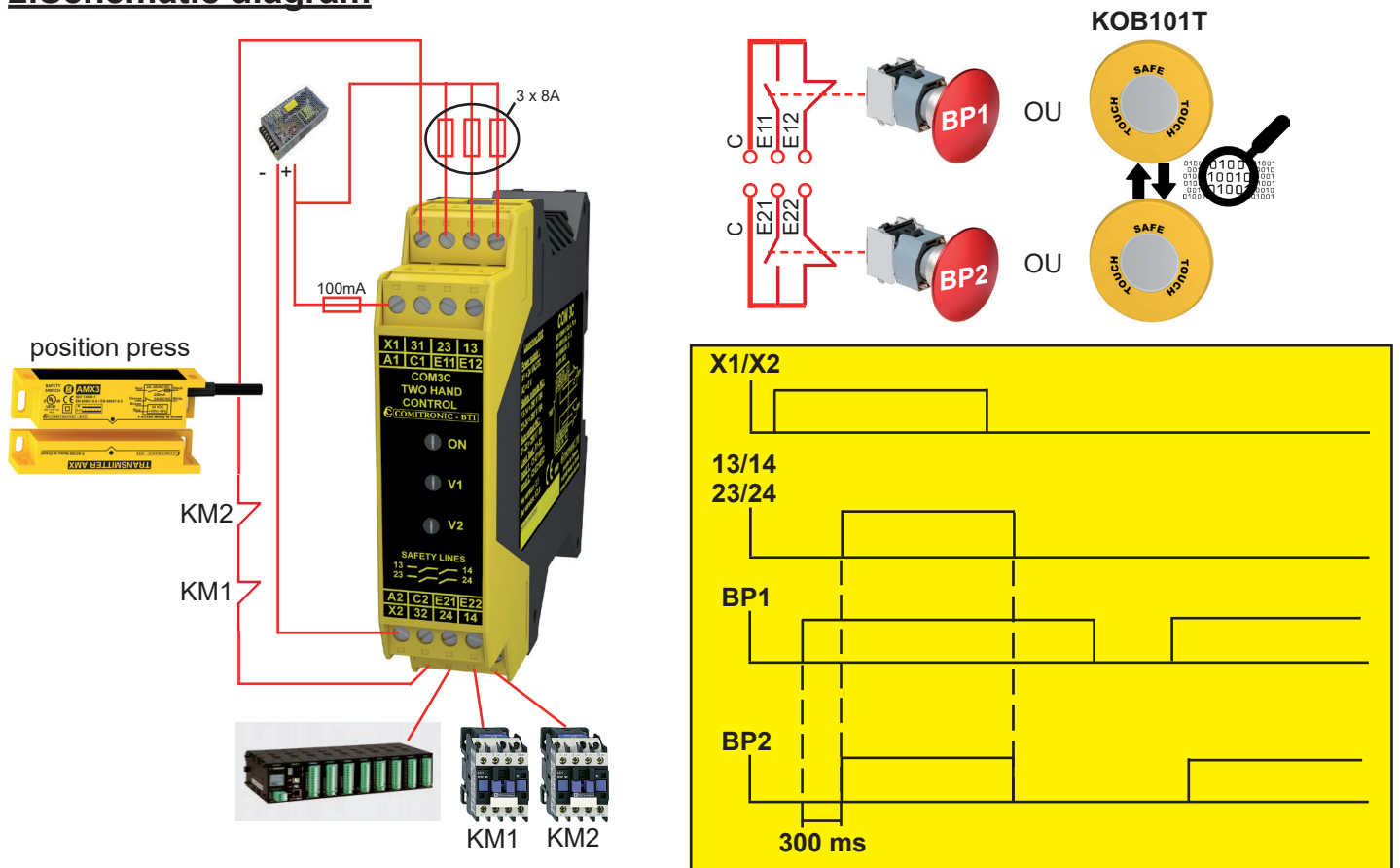

Two-hand control box COM3C

3. Dimensions

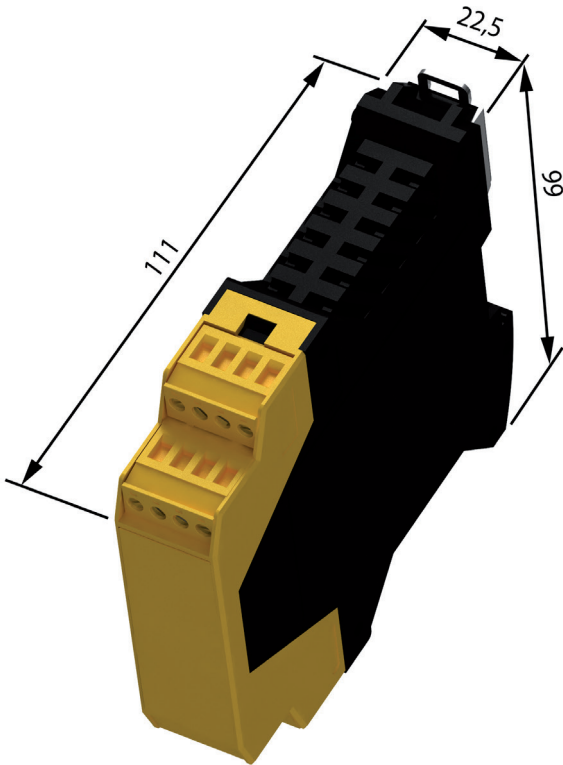

4. General specifications

| | |
|---|--|
| Supply voltage | 21~26 VAC/DC |
| Power supply | < 2W (DC) ; < 5VA (AC) |
| Electrical connection / tensioning | 14 AWG max (2.08mm ²) 250V min / 0.68 Nm |
| Safety contacts specifications IEC 60947-5-1 | 13/14, 23/24:NO 8 A/250 V pilot duty 31/32:NC // 8 A/250 V pilot duty |
| Desynchronized control inputs | E11/E12 = button 1, E21/E22 = button 2 |
| Desynchronization duration | 300 ms |
| Position control | X1/X2 |
| Time of Response | TR < 20 ms |
| Diagnostics | ON LED (red): power supply V1 LED (green): channel 1 activated (E11/E12) V2 LED (green): channel 2 activated (E21/E22) |
| Operating temperature | -20°C to +40°C (-4° to +104° F) |
| Water tightness / weight | IP 20 / 180 grams |
| Material / dimensions | Polyamide 6 / 22.5 x 100 x 111 mm |
| Periodic testing | Every 3 months |

Redundant safety relay C4SX and C5SX

Guided contact
EN 50205 type A



Breaking
capacity 4 x 6 A



Breaking
capacity 4 x 8 A

Check the
emergency stops

Interface
for OSSD outputs

C4SX: Safety contact extension relay for API C5SX: Contact extension relay of safety light curtain

1. Technological benefits

- Redundant output contacts = no additional wiring
- Removable screw terminal block and copper contact
- Relay status indicator: High-luminosity LED.
- C4SX: 1 input, 2 NO 6 A/250V contacts + 2 NO 6 A/125 V contacts + 1 NC test contact + 1 NC contact // 4 A/250 V
- C5SX: 2 inputs, + 2 contacts NO 8 A/250V + 2 contacts NO 8 A/125 V + 1 NC contact test + 1 NC contact // 4 A/250 V
- 24 VAC or DC power supply

2. Diagram of C4SX with API

3. Diagram of C4SX with AWAX

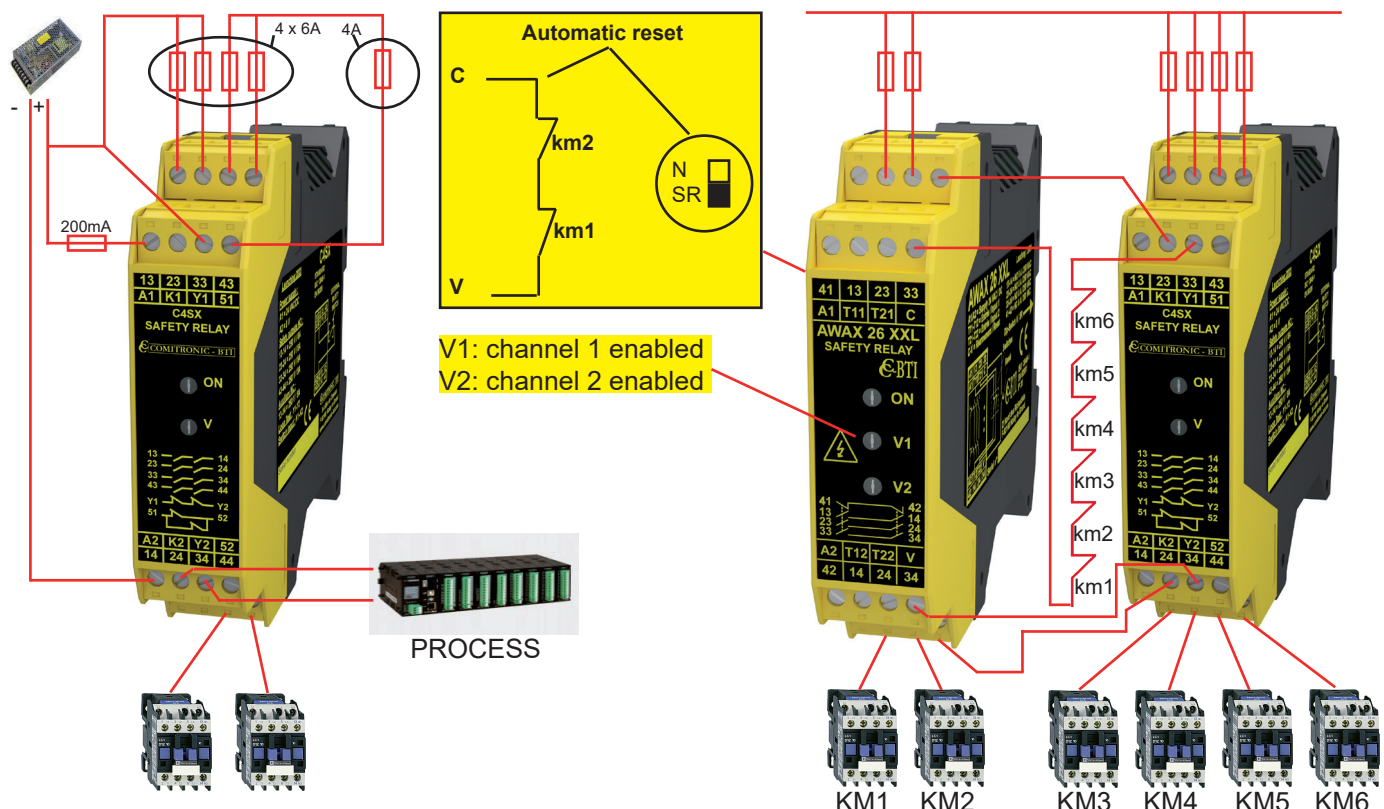

Redundant safety relay C4SX and C5SX

4. Schematic diagram of C5SX with safety light curtain

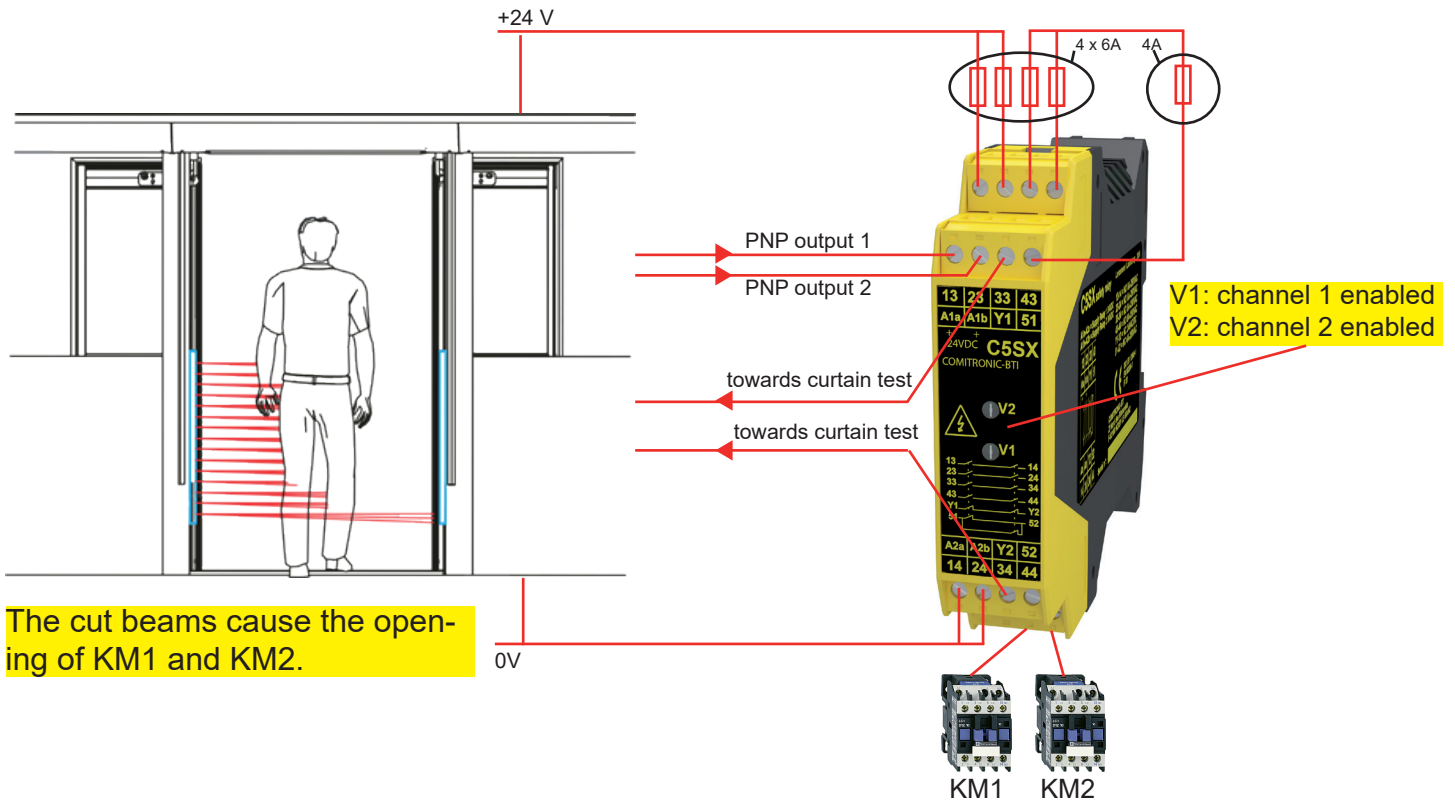

5. General specifications

| | |
|--|--|
| Supply voltage | 21~26 VAC/DC |
| Power supply | < 3.5W |
| Electrical connection / tensioning | 14 AWG max (2.08mm ²) 250V min / 0.68 Nm |
| Safety contacts specifications: C4SX(C5SX) IEC 60947-5-1 | 13/14, 23/24:NO 6(8) A/125 V pilot duty 33/34, 43/44:NO 6(8) A/250 V pilot duty 51/52:NC // 4 A/250 V pilot duty |
| Command inputs | C4SX:K1/K2 C5SX: channel 1 = A1a and channel 2 = A1b |
| Cyclical test contact | X1/X2 |
| Time of Response | TR < 20 ms |
| Diagnostics | ON LED (red): power supply V1 LED (green): channel 1 activated (E11/E12) V2 LED (green): channel 2 activated (E21/E22) |
| Operating temperature | -20°C to +60°C (-4° to +140° F) |
| Sealing | IP 20 |
| Material / dimensions | Polyamide 6 / 22.5 x 100 x 111 mm |
| Weight with packaging | 180 gr |

Redundant safety relay with consignment key:C4CK



Downgraded mode for maintenance with consignment key

1. Technological benefits

- Electric locking via free or captive
- Redundant output contacts = no additional wiring
- Removable screw terminal block and copper contact
- Relay status indicator: High-luminosity LED.
- 1 input, 2 NO 6 A/250V contacts + 2 NO 6 A/125 V contacts + 1 NC test contact + 1 NC contact // 4 A/250 V
- Version A: Captive key = lines 13/14, 23/24, 33/34, 43/44 are closed and lines X1/X2, 51/52 are open. Free key = lines 13/14, 23/24, 33/34, 43/44 are open and lines X1/X2, 51/52 are closed.
- Version B: Captive key = lines 13/14, 23/24, 33/34, 43/44 are open and lines X1/X2, 51/52 are closed. Free key = lines 13/14, 23/24, 33/34, 43/44 are closed and lines X1/X2, 51/52 are open.
- 24 VAC or DC power supply

2. Example of a schematic diagram of C4CK-A: Machine in operation

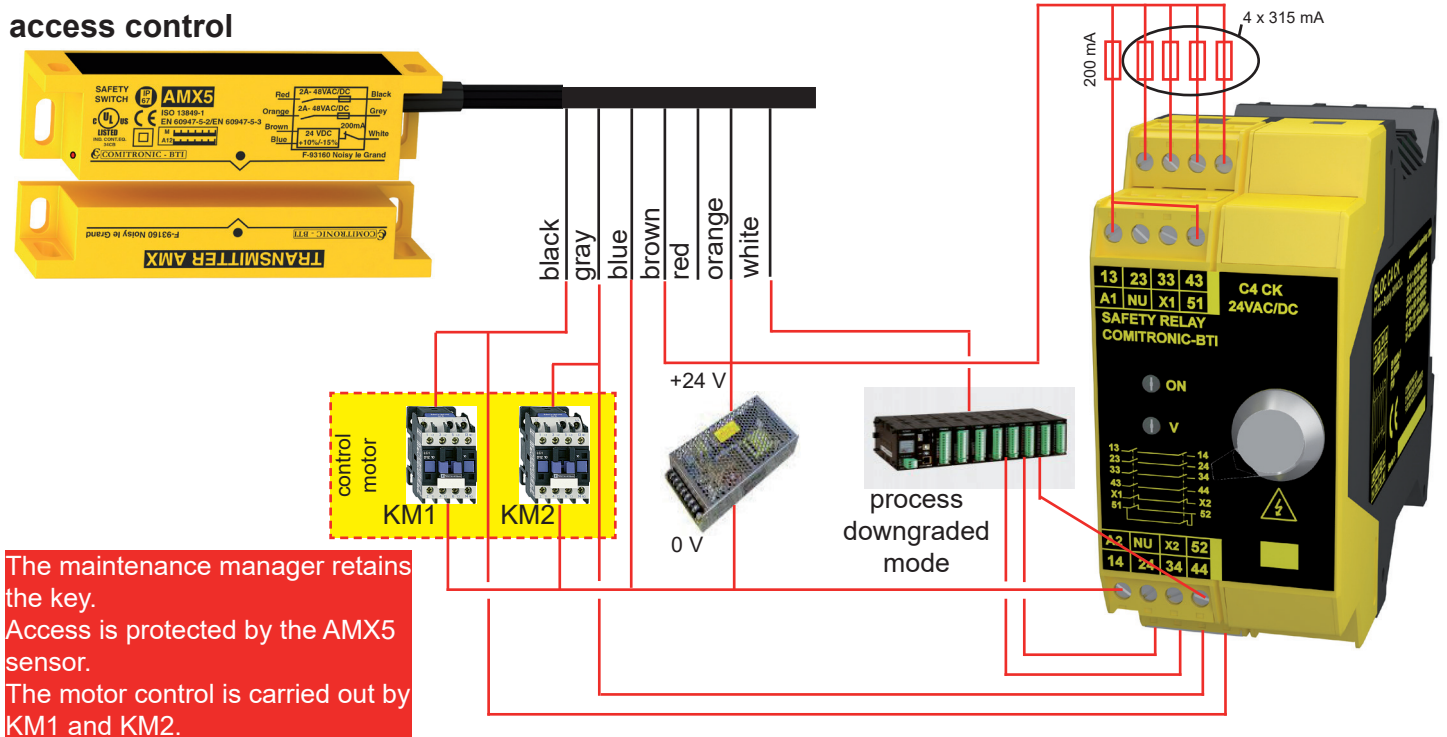

Redundant safety relay with consignment key: C4CK

3. Example of a schematic diagram of C4CK-A: downgraded mode

access control

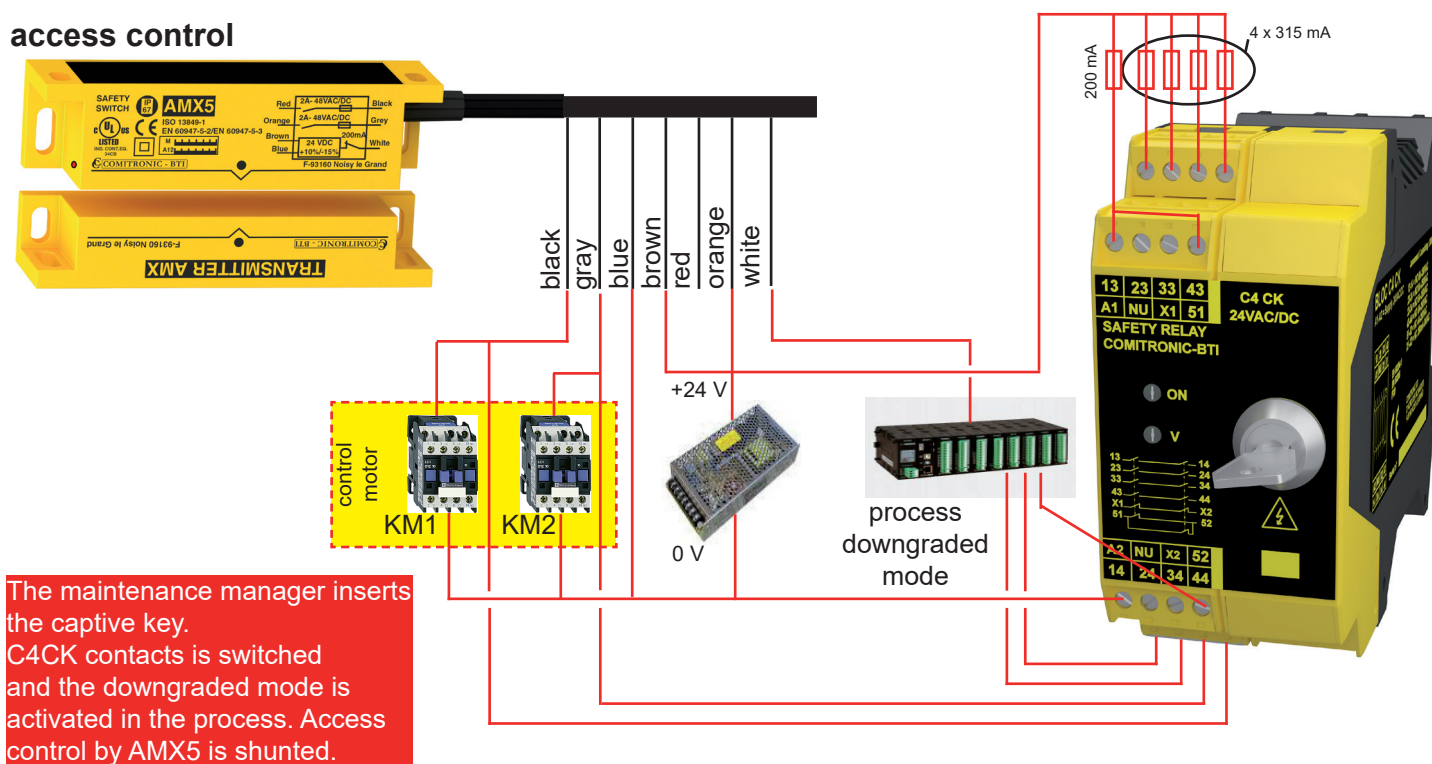

4. General specifications

| | |
|---|--|
| Supply voltage | 21~26 VAC/DC |
| Power supply | < 3.5W |
| Electrical connection / tensioning | 14 AWG max (2.08mm ²) 250V min / 0.68 Nm |
| Safety contacts specifications IEC 60947-5-1 | 13/14, 23/24:NO 6 A/125 V pilot duty 33/34, 43/44:NO 6 A/250 V pilot duty 51/52:NC // 4 A/250 V pilot duty |
| Command inputs | Key |
| Cyclical test contact | X1/X2 |
| Time of Response | TR < 20 ms |
| Diagnostics | ON LED (red): power supply V1 LED (green): channel 1 activated V2 LED (green): channel 2 activated |
| Operating temperature | -20°C to +60°C (-4° to +140° F) |
| Sealing | IP 20 |
| Material / dimensions | Polyamide 6 / 22.5 x 100 x 111 mm |
| Weight with packaging | 230 gr |

Safety relay RELTRONIC 6SX



Guided contact
EN 50205 type A

Breaking
capacity 6 x 8 A



Class A guided contact relays for adding supplementary power contacts

1. Technological benefits

- Adapted to machine safety
- Snap-on relay on DIN rail
- Removable screw terminal block and copper contact
- Activation LED
- Activation input: contact between C and V
- 4 NO contacts + 2 NC contacts 8A/250V
- 24V AC/DC power supply
- Control of inductive loads

2. schematic diagram

3. Dimensions



| Electrical specification | | | |
|--------------------------|-------|------|-------------------------|
| Type | 250 V | 24 V | B10d 10 ³ |
| AC1 | 8 A | | 500 |
| AC15 | 5 A | | 200 |
| DC13 | | 5 A | 300 |

| Mechanical specification | | |
|--------------------------|---------------------------|-------|
| Type | NO | NC |
| ON | 14 ms | |
| OFF | | 5 ms |
| Re-bounce | 6 ms | 30 ms |
| cycle 1 | 18000/h@I _n =0 | |
| cycle 2 | 360/h@I _n =8 A | |
| Endurance | 10 000 000 operation | |

| Control input (V) | |
|-------------------|-------|
| Current | 90 mA |

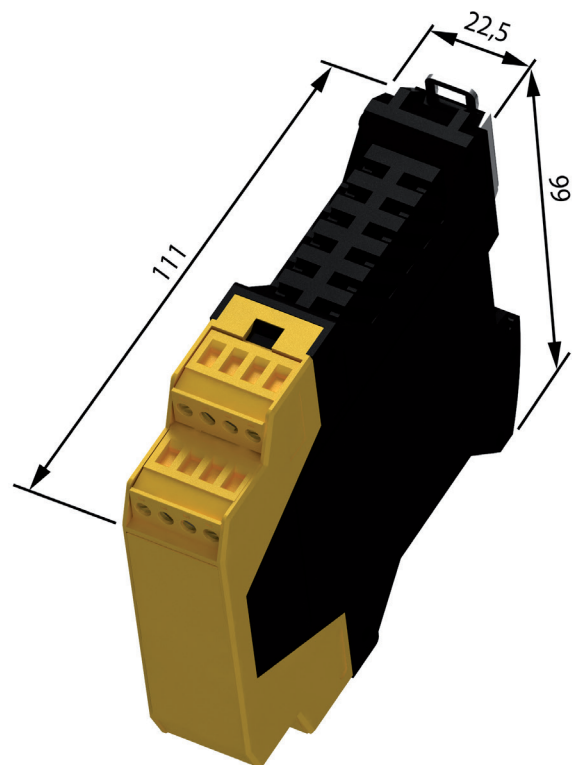

Zero speed control SPEEDTRONIC



Motor winding detection

Control of locking



Compatible variator

PL e cat.4

up to
3 x 690 Vac

Interlocking control system of machine safety by the rotation of an engine

1. Technological benefits

- Adapted to machine safety
- Snap-on relay on DIN rail
- Removable screw terminal block and copper contact
- Locking access as long as the engine is running
- 3 NO contacts (3 ports) + 1 NC 8A/250V contacts (hardware diagnostics)
- Diagnostics for PLC: PNP output "OK" and "ERROR"
- Consistency detection between motor windings
- Detection of motor winding break
- Adjustable delay between 3 and 10s
- Adjustable sensitivity between 20 mV and 700 mV
- Power supply 24V AC/DC

2. Example of a schematic diagram

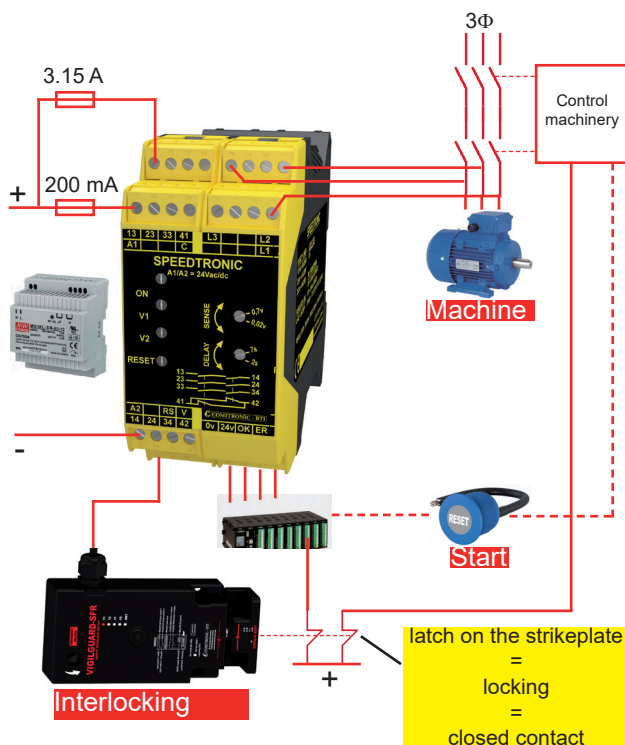

3. Dimensions

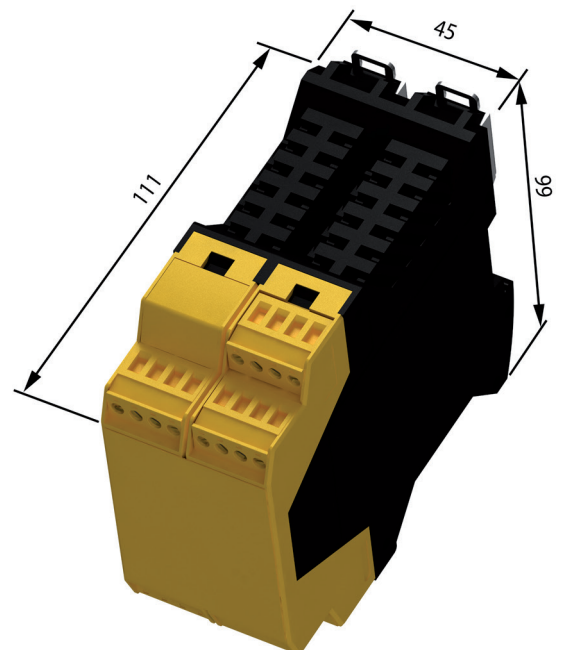

Zero speed control SPEEDTRONIC

4.General specifications

| | |
|---|--|
| Supply voltage | 21~26 VAC/DC |
| Power supply | 150 mA DC |
| Electrical connection / tensioning | 14 AWG max (2.08mm ²) 250V min / 0.68 Nm |
| Safety contacts specifications IEC 60947-5-1 | 13/14, 23/24, 33/34:NO 8 A/250 V pilot duty 41/42:NC // 8 A/250 V pilot duty |
| Command inputs | 3 x 690 VAC max. |
| Residual voltage detected | 20mV to 700mV adjustable on the front |
| Time of Response | TR < 20 ms |
| Delay of unlocking | adjustable by about 3 to 10s on the front |
| Diagnostics | ON LED (red): power supply V1 LED (green): channel 1 activated (L1/L2) V2 LED (green): channel 2 activated (L3/L2) |
| Operating temperature | -20°C to +60°C (-4° to +140° F) |
| Water tightness / weight | IP 20 / 300 grams |
| Material / dimensions | Polyamide 6 / 45 x 100 x 111mm |
| Periodic testing | 1/month |

Safety boxes

Wiring regulations and standard dimensions

1. Principle of wiring motor control contacts

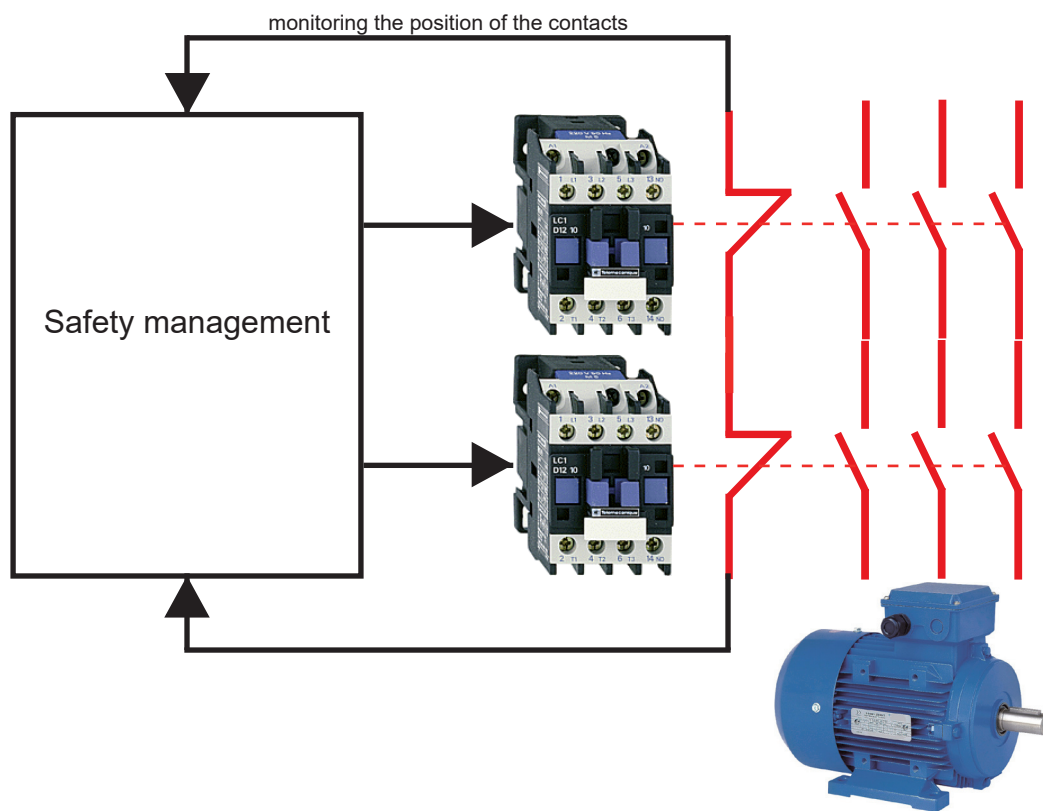

2. Model dimensions 22.5 mm

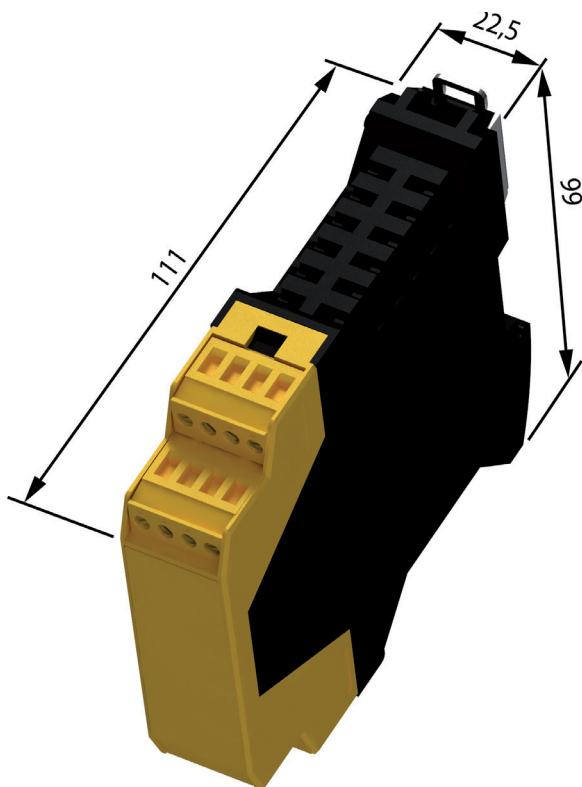

3. Model dimensions 45 mm

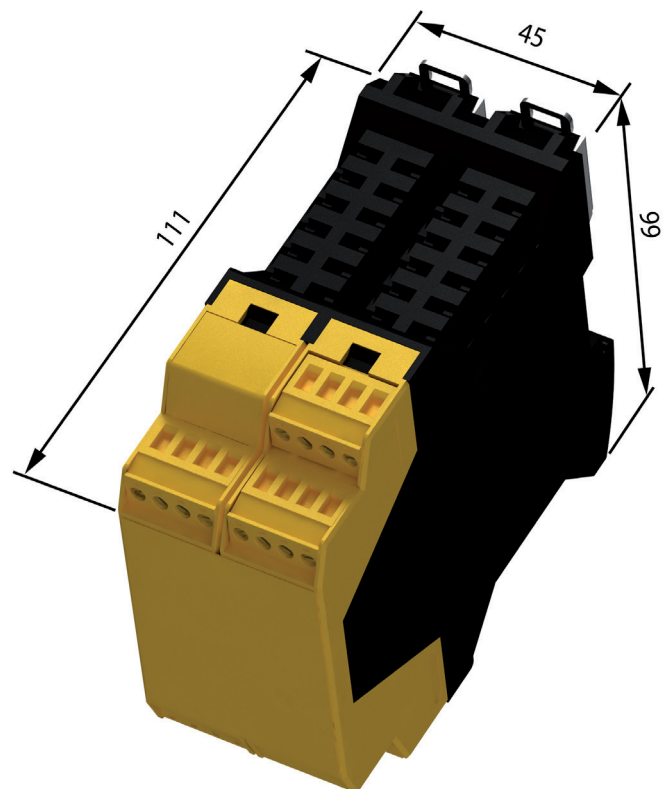

DÉCLARATION DE CONFORMITÉ



MANUFACTURER OF SAFETY MATERIAL
 14 Rue Pierre Paul de Riquet
 33610 Canéjan
 +33 5 64 10 04 52
 Web : www.comitronic.com



EU DECLARATION OF CONFORMITY

This document is the conformity declaration concerning safety switches and relays, conform to the
 Machine Directive 2006/42/CE, EMC Directive 2014/30/UE, RoHS2 Directive 2011/65/EU

ELECTROMECHANICAL SAFETY MODULES

| RANGE | STANDARD | VALUE |
|----------------|------------------------------|---|
| AWAX26XXL-485 | ISO 13849-1 | PL e, cat.4, DC 99%, CCF 100%, MTTFd 266y, TM 20y |
| | IEC 62061 | SIL CL 3 |
| | IEC 61508 | SIL 3, SFF 96%, PFHd = 9.81×10^{-9} , PFH = 5.10^{-9} , PFDavg = 55.10^{-6} |
| | IEC 60947-5-1 | 8 A / 250V, B10d=186 000 |
| | IEC 60204-1 | PELV, SELV |
| | IEC 61326-1 | Industrial application with additionnal IEC 61326-3-1 |
| | IEC 60068-2-1 | -25°C |
| | IEC 60068-2-2 | +70°C |
| | IEC 60068-2-14 | Temperature variation low, mid high |
| IEC 60068-2-30 | Damp heat cycle +55°C/95% RH | |

This product range is intended to monitor an emergency stop or safety sensor. Safety modules must be used following diagram and directives described in our data sheet.

It is recommended to test the system at least once a year.

Name of Technical authority :
 Christophe PAYS from
 COMITRONIC-BTI

Place and date of issue : Noisy, 21 July 2017

Authorised signature
 Christophe PAYS
 Technical manager

Serial number coding & example

YEAR WEEK NAME OPERATOR / NAME TEST MANAGER POSITION
 11 36 AB CD 03



MANUFACTURER OF SAFETY MATERIAL
 14 Rue Pierre Paul de Riquet
 33610 Canéjan
 +33 5 64 10 04 52
 Web : www.comitronic.com



EU DECLARATION OF CONFORMITY

This document is the conformity declaration concerning safety switches and relays, conform to the
 Machine Directive 2006/42/CE, EMC Directive 2014/30/UE, RoHS2 Directive 2011/65/EU

ELECTROMECHANICAL SAFETY MODULES

| RANGE | STANDARD | VALUE |
|-------------------------------|------------------------------|---|
| AWAX26XXL-T6 AWAX26XXLP-T6 | ISO 13849-1 | PL e, cat.4, DC 99%, CCF 100%, MTTFd 266y, TM 20y |
| | IEC 62061 | SIL CL 3 |
| | IEC 61508 | SIL 3, SFF 96%, PFHd = 9.81×10^{-9} , PFH = 5.10^{-9} , PFDavg = 55.10^{-6} |
| | IEC 60947-5-1 | 8 A / 250V, B10d=186 000 |
| | IEC 60204-1 | PELV, SELV |
| | IEC 61326-1 | Industrial application with additionnal IEC 61326-3-1 |
| | IEC 60068-2-1 | -25°C |
| | IEC 60068-2-2 | +70°C |
| | IEC 60068-2-14 | Temperature variation low, mid high |
| IEC 60068-2-30 | Damp heat cycle +55°C/95% RH | |

This product range is intended to monitor an emergency stop or safety sensor. Safety modules must be used following diagram and directives described in our data sheet.

It is recommended to test the system at least once a year.

Name of Technical authority :
 Christophe PAYS from
 COMITRONIC-BTI

Place and date of issue : Noisy, 21 July 2017

Authorised signature
 Christophe PAYS
 Technical manager

Serial number coding & example

YEAR WEEK NAME OPERATOR / NAME TEST MANAGER POSITION
 11 36 AB CD 03

DÉCLARATION DE CONFORMITÉ



MANUFACTURER OF SAFETY MATERIAL
 14 Rue Pierre Paul de Riquet
 33610 Canéjan
 +33 5 64 10 04 52
 Web : www.comitronic.com



EU DECLARATION OF CONFORMITY

This document is the conformity declaration concerning safety switches and relays, conform to the
 Machine Directive 2006/42/CE, EMC Directive 2014/30/UE, RoHS2 Directive 2011/65/EU

Intertek
5008891

ELECTROMECHANICAL SAFETY MODULES

| RANGE | STANDARD | VALUE |
|--------------------------------------|---------------------------|---|
| AWAX26XXL AWAX26XXLP AWAX27XXL | ISO 13849-1 | PL e, cat.4, DC 99%, CCF 90%, MTTFd 517y, TM 20y |
| | IEC 62061 | SIL CL 3 |
| | IEC 61508 | SIL 3 |
| | IEC 60947-5-1 | 8 A / 250V, B10d=100 000 |
| | IEC 60204-1 | PELV, SELV |
| | IEC 61326-1 | Industrial application with additionnal IEC 61326-3-1 |
| | IEC 60068-2-1 | -20°C |
| | IEC 60068-2-2 | +60°C |
| | UL Std. 508 | Conforms (not AWAX27XXL) |
| CSA C22.2 n°14 | Certified (not AWAX27XXL) | |

This product range is intended to monitor an emergency stop or safety sensor. Safety modules must be used following diagram and directives described in our data sheet.

It is recommended to test the system at least once a month.

Name of Technical authority :
 Christophe PAYS from
 COMITRONIC-BTI

Place and date of issue : Noisy, 21 July 2017

Authorised signature
 Christophe PAYS
 Technical manager

Serial number coding & example

YEAR WEEK NAME OPERATOR / NAME TEST MANAGER POSITION
 11 36 AB CD 03



MANUFACTURER OF SAFETY MATERIAL
 14 Rue Pierre Paul de Riquet
 33610 Canéjan
 +33 5 64 10 04 52
 Web : www.comitronic.com



EU DECLARATION OF CONFORMITY

This document is the conformity declaration concerning safety switches and relays, conform to the
 Machine Directive 2006/42/CE, EMC Directive 2014/30/UE, RoHS2 Directive 2011/65/EU

ELECTROMECHANICAL SAFETY MODULES

| RANGE | STANDARD | VALUE |
|------------|---------------|---|
| AWAX45XXL2 | ISO 13849-1 | PL e, cat.4, DC 99%, CCF 90%, MTTFd 517y, TM 20y |
| | IEC 62061 | SIL CL 3 |
| | IEC 61508 | SIL 3 |
| | IEC 60947-5-1 | 8 A / 250V, B10d=100 000 |
| | IEC 61326-1 | Industrial application with additionnal IEC 61326-3-1 |
| | IEC 60068-2-1 | -20°C |
| | IEC 60068-2-2 | +60°C |

This product range is intended to monitor an emergency stop or safety sensor. Safety modules must be used following diagram and directives described in our data sheet.

It is recommended to test the system at least once a month.

Name of Technical authority :
 Christophe PAYS from
 COMITRONIC-BTI

Place and date of issue : Noisy, 21 July 2017

Authorised signature
 Christophe PAYS
 Technical manager

Serial number coding & example

YEAR WEEK NAME OPERATOR / NAME TEST MANAGER POSITION
 11 36 AB CD 03

DÉCLARATION DE CONFORMITÉ



MANUFACTURER OF SAFETY MATERIAL
 14 Rue Pierre Paul de Riquet
 33610 Canéjan
 +33 5 64 10 04 52
 Web : www.comitronic.com



EU DECLARATION OF CONFORMITY

This document is the conformity declaration concerning safety switches and relays, conform to the
 Machine Directive 2006/42/CE, EMC Directive 2014/30/UE, RoHS2 Directive 2011/65/EU

ELECTROMECHANICAL SAFETY MODULES

| RANGE | STANDARD | VALUE |
|----------|---------------|--|
| CO13 XXL | ISO 13849-1 | PL d, cat.3, DC 90%, CCF 65%, MTTFd 240y, TM 20y |
| | IEC 60947-5-1 | 8 A / 250V, B10d=100 000 |
| | IEC 60204-1 | PELV, SELV |
| | IEC 60068-2-1 | -20°C |
| | IEC 60068-2-2 | +60°C |

This product range is intended to monitor an emergency stop or safety sensor. Safety modules must be used following diagram and directives described in our data sheet.

It is recommended to test the system at least once a year.

Name of Technical authority :
 Christophe PAYS from
 COMITRONIC-BTI

Place and date of issue : Noisy, 21 July 2017

Authorised signature
 Christophe PAYS
 Technical manager

Serial number coding & example

YEAR WEEK NAME OPERATOR / NAME TEST MANAGER POSITION
 11 36 AB CD 03



MANUFACTURER OF SAFETY MATERIAL
 14 Rue Pierre Paul de Riquet
 33610 Canéjan
 +33 5 64 10 04 52
 Web : www.comitronic.com



EU DECLARATION OF CONFORMITY

This document is the conformity declaration concerning safety switches and relays, conform to the
 Machine Directive 2006/42/CE, EMC Directive 2014/30/UE, RoHS2 Directive 2011/65/EU

ELECTROMECHANICAL SAFETY MODULES

| RANGE | STANDARD | VALUE |
|-------|---------------|--|
| COM3C | ISO 13849-1 | PL e, cat.4, DC 99%, CCF 90%, MTTFd 190y, TM 20y |
| | IEC 61508 | SIL 3 |
| | IEC 62061 | SIL CL 3 |
| | IEC 60947-5-1 | 8 A / 250V, B10d=100 000 |
| | IEC 60204-1 | PELV, SELV, stop function : cat.0 |
| | IEC 60068-2-1 | -20°C |
| | IEC 60068-2-2 | +40°C |

This product range is intended to monitor an emergency stop or safety sensor. Safety modules must be used following diagram and directives described in our data sheet.

The product COM3C must be tested once a year. If the product is not used for a period exceeding 3 months, it must also be tested.

Name of Technical authority :
 Christophe PAYS from
 COMITRONIC-BTI

Place and date of issue : Noisy, 21 July 2017

Authorised signature
 Christophe PAYS
 Technical manager

Serial number coding & example

YEAR WEEK NAME OPERATOR / NAME TEST MANAGER POSITION
 11 36 AB CD 03

DÉCLARATION DE CONFORMITÉ



MANUFACTURER OF SAFETY MATERIAL
 14 Rue Pierre Paul de Riquet
 33610 Canéjan
 +33 5 64 10 04 52
 Web : www.comitronic.com



EU DECLARATION OF CONFORMITY

This document is the conformity declaration concerning safety switches and relays, conform to the
 Machine Directive 2006/42/CE, EMC Directive 2014/30/UE, RoHS2 Directive 2011/65/EU

ELECTROMECHANICAL SAFETY MODULES

| RANGE | STANDARD | VALUE |
|----------------------|---------------|--------------------------|
| C4SX C5SX C4CK | EN 50205 | Class A forced contact |
| | IEC 60947-5-1 | 8 A / 250V, B10d=100 000 |
| | IEC 60068-2-1 | -20°C |
| | IEC 60068-2-2 | +60°C |

This product range is intended to monitor an emergency stop or safety sensor. Safety modules must be used following diagram and directives described in our data sheet.

It is recommended to test the system at least once a year.

Name of Technical authority :
 Christophe PAYS from
 COMITRONIC-BTI

Serial number coding & example
 YEAR WEEK NAME OPERATOR / NAME TEST MANAGER POSITION
 11 36 AB CD 03

Place and date of issue : Noisy, 21 July 2017
 Authorised signature
 Christophe PAYS
 Technical manager



MANUFACTURER OF SAFETY MATERIAL
 14 Rue Pierre Paul de Riquet
 33610 Canéjan
 +33 5 64 10 04 52
 Web : www.comitronic.com



EU DECLARATION OF CONFORMITY

This document is the conformity declaration concerning safety switches and relays, conform to the
 Machine Directive 2006/42/CE, EMC Directive 2014/30/UE, RoHS2 Directive 2011/65/EU

ELECTROMECHANICAL SAFETY MODULES

| RANGE | STANDARD | VALUE |
|---------------|---------------|--------------------------|
| RELTRONIC 6SX | EN 50205 | Class A, guided contact |
| | IEC 60947-5-1 | 8 A / 250V, B10d=100 000 |
| | IEC 60204-1 | PELV, SELV |
| | IEC 60068-2-1 | -20°C |
| | IEC 60068-2-2 | +60°C |

This product range is intended to monitor an emergency stop or safety sensor. Safety modules must be used following diagram and directives described in our data sheet.

The product must be tested each 1 year. If the product is not used for a period exceeding 3 months, it must also be tested.

Name of Technical authority :
 Christophe PAYS from
 COMITRONIC-BTI

Serial number coding & example
 YEAR WEEK NAME OPERATOR / NAME TEST MANAGER POSITION
 11 36 AB CD 03

Place and date of issue : Noisy, 21 July 2017
 Authorised signature
 Christophe PAYS
 Technical manager

DÉCLARATION DE CONFORMITÉ



MANUFACTURER OF SAFETY MATERIAL
 14 Rue Pierre Paul de Riquet
 33610 Canéjan
 +33 5 64 10 04 52
 Web : www.comitronic.com



EU DECLARATION OF CONFORMITY

This document is the conformity declaration concerning safety switches and relays, conform to the Machine Directive 2006/42/CE, EMC Directive 2014/30/UE, RoHS2 Directive 2011/65/EU

ELECTROMECHANICAL SAFETY MODULES

| RANGE | STANDARD | VALUE |
|-------------|---------------|--|
| SPEEDTRONIC | ISO 13849-1 | PL e, cat.4, DC 99%, CCF 65%, MTTFd 100y, TM 20y |
| | IEC 60947-5-1 | 8 A / 250V, B10d=100 000 |
| | IEC 60204-1 | PELV, SELV |
| | IEC 60068-2-1 | -20°C |
| | IEC 60068-2-2 | +60°C |

This product range is intended to monitor an emergency stop or safety sensor. Safety modules must be used following diagram and directives described in our data sheet.

The product must be tested each 6 month. If the product is not used for a period exceeding 3 months, it must also be tested.

Name of Technical authority :
 Christophe PAYS from
 COMITRONIC-BTI

Serial number coding & example

YEAR WEEK NAME OPERATOR / NAME TEST MANAGER POSITION
 11 36 AB CD 03

Place and date of issue : Noisy, 21 july 2017

Authorised signature
 Christophe PAYS
 Technical manager

FORMATION DIPLÔMANTE

Our TÜV Rheinland certified trainer is at your disposal to learn:

- to use ISO 13849-1
- to justify the CE marking of a dangerous machine to the authorities
- to realize the obligatory safety file of a dangerous machine

At the end of the two-day training, a test in the form of an QCM will allow candidates to obtain a diploma attesting to their ability to evaluate the objectives to reach the standard.



14 Rue Pierre Paul de Riquet
33610 Canéjan
+33 5 64 10 04 52
www.comitronic-bti.com

